



Carrollton Public Schools

MIDDLE SCHOOL GYM RTU REPLACEMENT

SAGINAW, MICHIGAN

5/29/2026



Carrollton Public Schools

PROJECT: Carrollton Public Schools
Middle School Gym RTU Replacement

PROJECT LOCATION: Carrollton Public Schools
3211 Carla Drive
Saginaw, MI 48604

OWNERS REPRESENTATIVE: Brady Dangler
Director of Facilities
Carrollton Public Schools



Carrollton Public Schools

Advertisement for bid:

Notice is hereby given that Carrollton Public Schools is receiving bids from trade contractors for the following project:

Middle School Gym RTU Replacement

Bids will be received at the Office of the Superintendent at 11:00 am, Thursday, June 18th 2026 at which time the bids will be publicly opened and read aloud.

Proposals should be submitted and be addressed to:

Tiffany Peterson - Superintendent
Carrollton Public Schools
3211 Carla Drive
Saginaw, MI 48604

The Owner reserves the right to reject any, part of any or all bids and to waive all informalities in the bidding procedures. The Owner reserves the right to reject any bid when Bidder fails to submit data required by the Bidding Documents, or if the bid is submitted incomplete or irregular. No telephonic, telegraphic, email, fax bids or modification to a submitted bid will be received or considered by the Owner.

Bids may not be withdrawn for a period of sixty (60) days after the bid date.

5% Bid and Performance Bond & Labor and Material Payment Bond are required if bid is \$50,000 and greater.

Pre-bid Meeting Scheduled for Wednesday, June 10th, at 11 a.m. Prospective Contractors should RSVP to Brady Dangler at bdangler@gocavs.net or 989-339-4222. Upon arrival, please check in to the middle school main office in the BACK of the school, located at 3211 Carla Drive, Saginaw, MI 48604.



Carrollton Public Schools

Scope of Work

Carrollton Public Schools is requesting proposals to completely remove the existing RUUD rooftop unit that serviced the middle school gym and furnish and install a new 20 ton Trane Precedent RTU. The selected contractor will furnish all labor, materials, equipment, permits, and coordination to deliver a fully operational and fully up to code system that adequately services the gym. The complete bid shall include, but is not limited to:

- Removal and disposal of old RTU
- Furnish and install new, specified RTU
- Any necessary roof and asphalt protection for the crane lift and new RTU installation
- The reuse or plans to replace the existing support steel for new RTU and ductwork
- Any necessary mechanical or structural engineering for the new RTU
- Testing, commissioning and balancing
- All controls work to be included
- All electrical work to be included
- Any and all duct and gas hook ups, tie ins, and modifications to existing infrastructure to accept the new RTU
- Repairs of any roof damage or modifications made to be performed by certified installers
- Duct insulation
- All necessary permits and inspections
- Professional startup and training
- Any necessary modifications to make the new RTU fully code compliant
- All necessary duct detectors to be furnished and installed by contractor and wired into the existing fire panel located in the Central Office. (The current unit does not have any duct detectors installed.)

This project is subject to prevailing wage.

TIMELINE

- RFP Issued: Wednesday, June 4th
- Pre-bid Meeting: Wednesday, June 10, at 11 a.m.
- RFP Due Date: Thursday, June 18th at 11 a.m.
- Anticipated School Board Action: TBD



Carrollton Public Schools

SCHEDULE

This project is to be completed during the summer vacation beginning on June 5th and has a hard **substantial completion date of August 7th, 2026**. All crane lifts and other possible disturbances to parking, traffic flow, or students' ability to learn, must be scheduled on days that school is not in session as to minimise disruption to normal operations.



Carrollton Public Schools

Site Conditions

The rooftop unit is located in the center of the middle school.

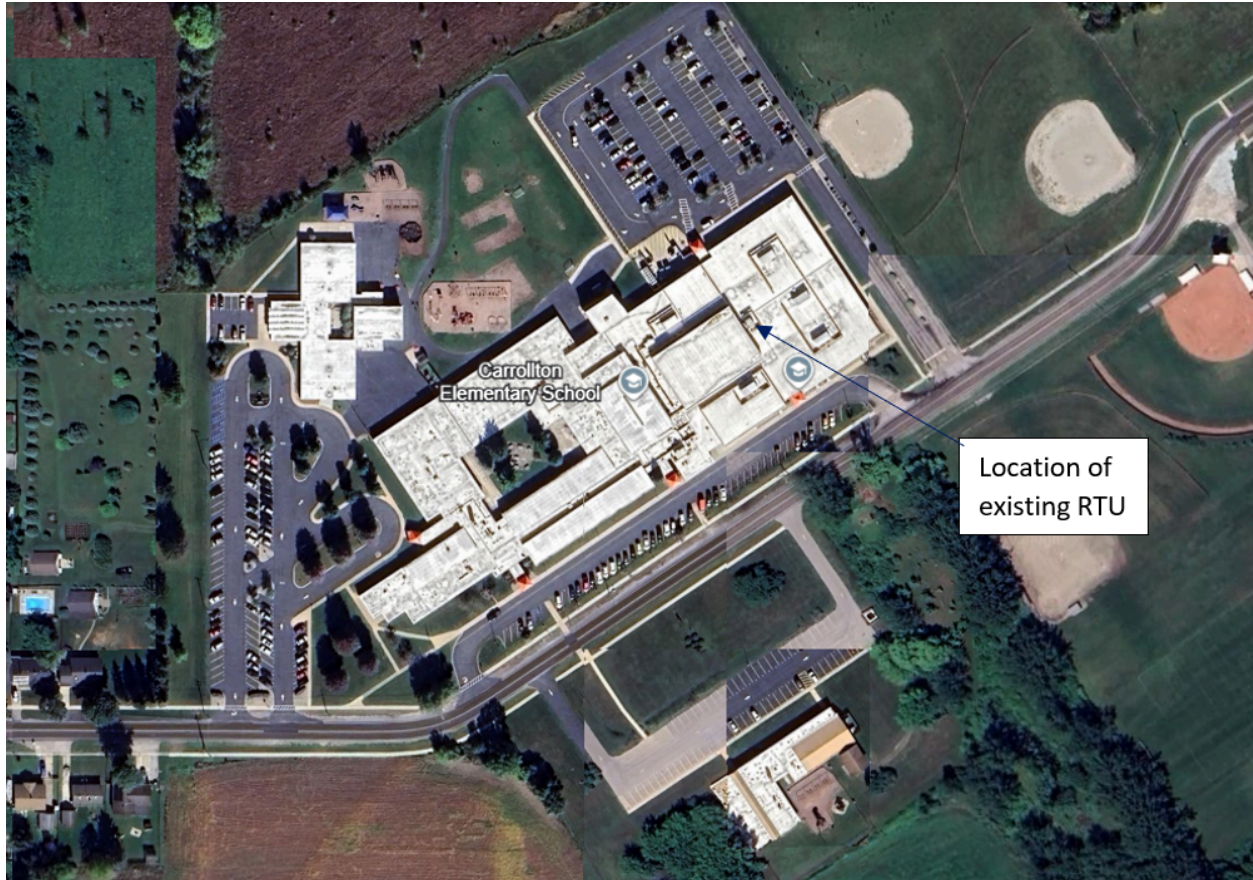

- ★ Contractor shall field verify all measurements and necessary specifications to replace the existing rooftop unit.



Exiting Unit

- Manufacturer: RUUD
- Model: unknown
- Capacity (tons): unknown
- Voltage/Phase: 480v 3 phase
- Heating Type (Gas/Electric/Heat Pump): Gas
- Service Area: Carrollton Middle School Gym





Carrollton Public Schools

New Unit:

20 ton Precedent Unitary Rooftop Unit (furnished and installed by contractor)

Model Number: YSK240A4S0H

Submittal

Prepared For:

All Bidders

Date: May 18, 2026

Job Name:

Carrollton Middle School - Gym RTU 031626

Opportunity ID: 8628506

Trane U.S. Inc. is pleased to provide the following submittal for your review and approval.

Product Summary

Qty Product

1 3 - 25 Ton Precedent Unitary Rooftop



Carrollton Public Schools

Table of Contents

Product Summary.....	1
3 - 25 Ton Precedent Unitary Rooftop (Item A1).....	3
Tag Data.....	3
Product Data.....	3
Performance Data.....	4
Mechanical Specifications.....	6
Dimensional Drawings.....	8
Weight, Clearance & Rigging.....	10
Accessory.....	11
Field	
Wiring.....	12
Field Installed Options - Part/Order Number Summary.....	14
3 - 25 Ton Precedent Unitary Rooftop.....	14



Carrollton Public Schools

Tag Data - 3 - 25 Ton Precedent Unitary Rooftop (Qty: 1)

Item	Tag(s)	Qty	Description	Model Number
A1	PREC-1	1	3 - 25 Ton Precedent Unitary Rooftops (P	YSK240A4S0H

Product Data - 3 - 25 Ton Precedent Unitary Rooftop

Item: A1 Qty: 1 Tag(s): PREC-1

DX Cooling / Gas Heat

Standard Efficiency

R-454B Refrigerant

20 Ton

460/60/3

Symbio 700 unit controls

High capacity gas heat

Multi-speed motor

3-year parts, coils & controls warranty

5-year compressor parts only warranty

10-year aluminized heat exchanger parts only warranty

Fresh Air Option Module (Field Installed)

0-100% Low Leak Economizer kit, dry bulb control (Field Installed)

3H/2C programmable touchscreen thermostat (Field Installed)

Discharge air sensing tube (Field Installed)

Year 1 Labor whole unit



Carrollton Public Schools

Performance Data - 3 - 25 Ton Precedent Unitary Rooftop

Tags	PREC-1
Cooling Entering Dry Bulb (F)	80.00
Cooling Entering Wet Bulb (F)	67.00
Summer Ambient (F)	95.00
Heating Entering Air Temperature (F)	70.00
Design Airflow (cfm)	8000
Airflow Application	Downflow
Design ESP (in H2O)	0.500
Gross Total Capacity (MBh)	249.20
Gross Sensible Capacity (MBh)	186.92
Net Total Capacity (MBh)	241.77
Net Sensible Capacity (MBh)	179.49
Coil LAT DB (F)	58.43
Coil LAT WB (F)	56.94
Cooling Leaving Unit Dry Bulb (F)	59.83
Cooling Leaving Unit WB (F)	57.50
Dew Point Temperature (F)	56.01
Supply Motor Horsepower (hp)	3.000
Total Supply Operating Horsepower (hp)	2.950
Compressor Power (kW)	17.83
System Power (kW)	24.82
EER @ AHRI	9.80
IEER @ AHRI	13.00
MCA (A)	55.00
MOP (A)	70.00
Heating Input Capacity (MBh)	400.00
Output Heating Capacity (MBh)	324.00
Heating Leaving Air Temperature (F)	107.17
Heating Temperature Rise (F)	37.17
Height (ft)	4.92
Width (ft)	7.25
Length (ft)	10.25
Approx Installed Weight (lb)	2256.0
Supply Fan Count	2



Carrollton Public Schools

**Mechanical Specifications - 3 - 25 Ton Precedent Unitary Rooftop
Item: A1 Qty: 1 Tag(s): PREC-1**

General (6-25 Ton)

The packaged rooftop unit's cooling capacities, heating capacities, and efficiencies are certified to AHRI Standard 210/240. It is listed to UL standard 60335-2-40. The gas heating units comply with ANSI Z21.47 and 10 CFR Part 431 for Commercial Warm Air. The unit features convertible airflow and is controlled by Symbio, which operates within a range of 40°F to 125°F in cooling mode as standard from the factory. It is factory-assembled, internally wired, fully charged, and 100 percent run-tested to verify cooling operation, fan and blower rotation, and control sequence before leaving the factory. The Fault Detection and Diagnostics (FDD) system meets the mandatory requirements of CA Title 24, offering fully configurable diagnostics that allow fault history and reading fault codes at the unit via the Symbio 700 board or app. The FDD system detects faults such as air temperature sensor failure/fault and notification of acceptable economizer mode, and it is certified by the Energy Commission as meeting these requirements. The unit features colored and numbered wiring internally for simplified identification and is cULus listed and classified in accordance with Central Cooling Air Conditioners. Additionally, the unit shall be furnished with a leak detection system from the factory, consisting of one or more refrigerant detection sensors. When the system detects a leak, the unit controller shall initiate mitigation actions.

Casing

The unit casing is constructed from zinc-coated, heavy-gauge, galvanized steel and features weather-resistant pre-painted metal with a galvanized substrate. It meets the ASTM B117 standard for a 672-hour salt spray test. The unit includes removable single-side maintenance access panels, which are equipped with lifting handles. These handles can be removed and reinstalled by removing fasteners, while still providing a water and airtight seal. The exposed vertical panels and top covers in the indoor air section are insulated with a cleanable, foil-faced, fire-retardant, permanent, odorless glass fiber material. The base pan has no penetrations within the perimeter of the curb, except for the raised 1-inch high downflow supply/return openings, which provide an added water integrity precaution in case the condensate drain backs up. The condensate connection is available through the base or through the side. The base of the unit is insulated with 1/8 inch, foil-faced, closed-cell insulation. Additionally, the unit base includes provisions for forklift and/or crane lifting on three sides of the unit.

Compressors (20- 25 Ton)

All units are equipped with direct-drive, hermetic, scroll-type compressors featuring centrifugal-type oil pumps. The compressors have suction gas-cooled motors with a voltage utilization range of plus or minus 10 percent of the unit nameplate voltage. Internal overloads are standard with scroll compressors, and crankcase heaters are



Carrollton Public Schools

included on all compressors. The units feature dual compressors and four stages of cooling.

Indoor Fan (6-25 Ton)

The indoor fan features a direct drive plenum fan design with a backward-curved fan wheel and an external rotor direct drive variable speed indoor motor. Supply fan speed adjustments can be made using the Symbio 700 or Mobile App. The motors are electronically protected and are high-efficiency variable speed direct drive motors.

Evaporator and Condenser Coils

The evaporator and condenser coils feature optimal heat transfer performance due to flat, streamlined tubes with small ports and a metallurgical tube-to-fin bond. This design reduces the system refrigerant charge by up to 50 percent, leading to better compressor reliability. The compact all-aluminum microchannel coils reduce the unit's weight and are fully recyclable, minimizing galvanic corrosion due to their all-aluminum construction. The strong aluminum brazed structure provides better fin protection, while the flat streamlined tubes are more dust-resistant and easy to clean. Additionally, the coils are leak-tested at the factory to verify their pressure integrity.

Phase Monitor

Phase monitor protects 3-phase equipment from phase loss, phase reversal and phase imbalance. Any fault condition shall produce a Failure Indicator LED and send the unit into an auto stop condition.

Gas Heating Section

The compact cabinet features a tubular heat exchanger available in low, medium, and high heat capacities. Corrosion-resistant aluminized steel tubes and burners are standard on all models. An induced draft combustion blower is used to pull the combustion products through the firing tubes. The heater utilizes a direct spark ignition (DSI) system and a flame sensor as a safety device to validate the flame.

Standard Filters

Standard 2-inch filters.

Standard Drain Pan (12.5-25 Ton)

The standard drain pan features an easy-to-clean, composite, removable, dual-sloped drain pan designed for improved indoor air quality (IAQ).

Frostat

The Frostat is used as a safety mechanism, designed to open to prevent freezing temperatures on the evaporator coil. It closes when the temperature rises to 50°F. This device is particularly utilized in low airflow or high outside air applications, specifically in cooling-only scenarios.



Carrollton Public Schools

Coil Guards

Coil Guards are factory installed to provide condenser coil protection during shipping and from hail, vandals, wind, and other damage. The toolless design lends itself to ease of maintenance in cleaning coils.

Low Leak Economizer (Field Installed)

The Low Leak Economizer meets the requirements for ASHRAE 90.1, IECC, and CA Title 24 standards (4 cfm/ft² @ 1 inch wg for exterior air/return air). This option allows 0 to 100 percent outdoor air supply through modulating dampers and comes standard with barometric relief. It can be paired with power exhaust for additional building pressure relief. This option can be paired with or without fault detection and diagnostics (FDD) to meet current mandatory CA Title 24 requirements.



Carrollton Public Schools

Dimensional Drawings - 3 - 25 Ton Precedent Unitary Rooftop Item: A1 Qty: 1 Tag(s): PREC-1

- NOTES:
1. THRU -THE -BASE ELECTRICAL IS NOT STANDARD ON ALL UNITS.
2. VERIFY WEIGHTS, CONNECTIONS, AND ALL DIMENSIONS WITH
INSTALLER DOCUMENTS BEFORE INSTALLATION

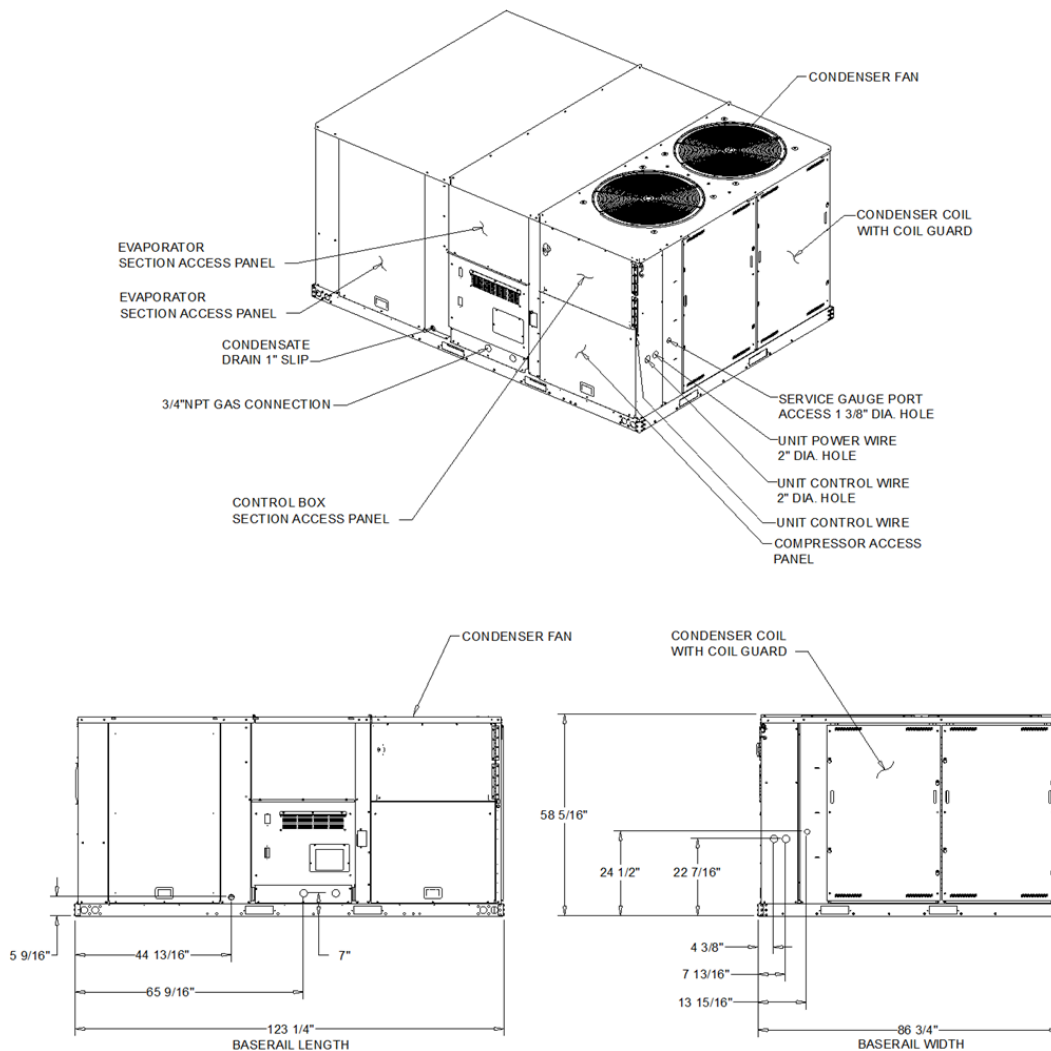

DX COOLING / GAS HEAT STANDARD EFFICIENCY

DIMENSION DRAWING



Carrollton Public Schools

Dimensional Drawings - 3 - 25 Ton Precedent Unitary Rooftop

Item: A1 Qty: 1 Tag(s): PREC-1

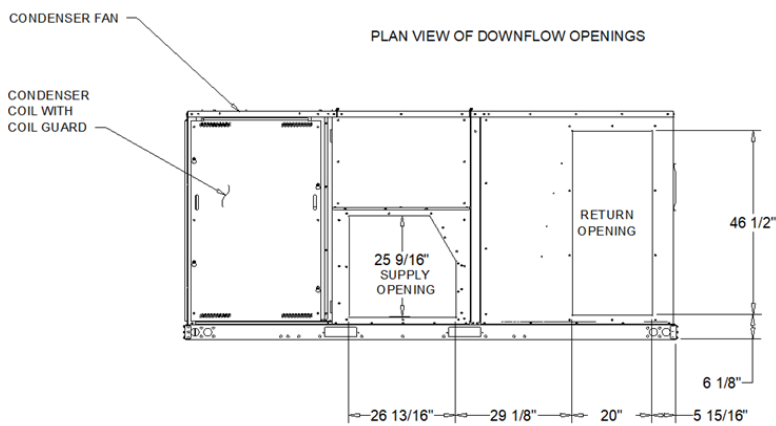
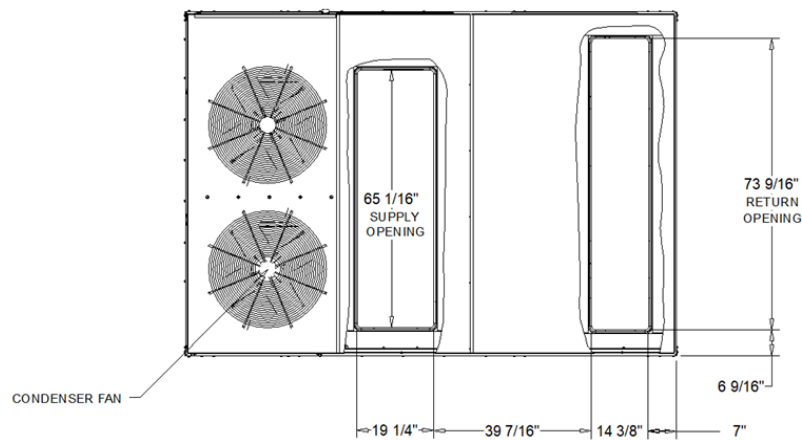

PLAN VIEW OF DOWNFLOW OPENINGS

HORIZONTAL AIR FLOW OPENING

DX COOLING / GAS HEAT STANDARD EFFICIENCY

DIMENSION DRAWING



Carrollton Public Schools

Weight, Clearance & Rigging - 3 - 25 Ton Precedent Unitary Rooftop

Item: A1 Qty: 1 Tag(s): PREC-1

- NOTES:
1. APPROX. INSTALLED WEIGHT INCLUDES ALL SELECTED OPTIONS AND ACCESSORIES.
 2. CORNER WEIGHTS ARE FOR BASE UNIT ONLY AND DO NOT INCLUDE OPTIONS OR ACCESSORIES.
 3. WEIGHT INCLUDES BOTH FACTORY AND FIELD INSTALLED ACCESSORY.
 4. WHEN EQUIPPED WITH ECONOMIZER OR BAROMETRIC RELIEF DAMPER, CLEARANCE DISTANCE IS TO BE MEASURED FROM PROTRUDING HOOD INSTEAD OF BASE.

Approximate Installed Weight: 2,256.0 lb

(A) Corner Weight: 754.0 lb

(C) Corner Weight: 337.0 lb

(B) Corner Weight: 516.0 lb

(D) Corner Weight: 493.0 lb

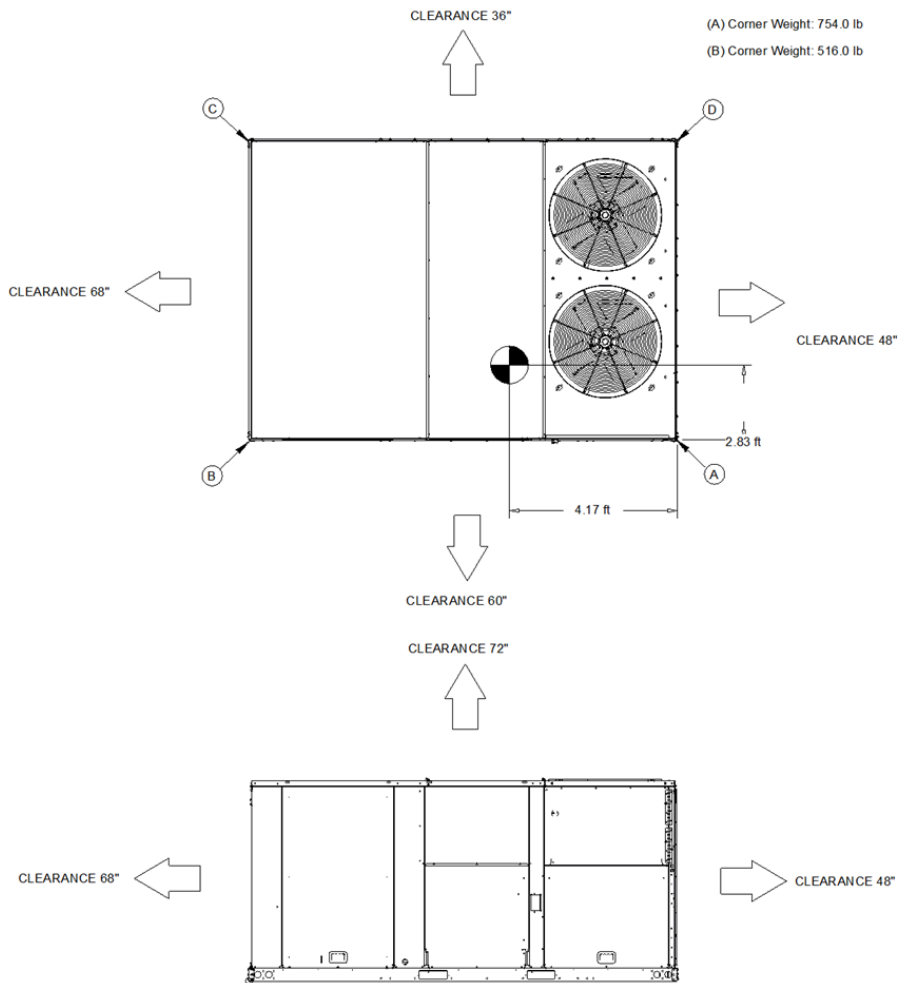

DX COOLING / GAS HEAT STANDARD EFFICIENCY

WEIGHTS AND CLEARANCES



Carrollton Public Schools

Accessory - 3 - 25 Ton Precedent Unitary Rooftop

Item: A1 Qty: 1 Tag(s): PREC-1

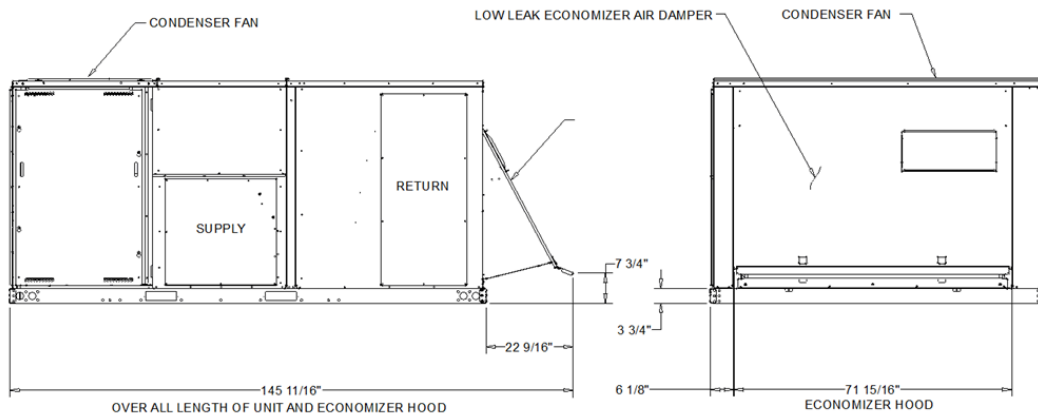
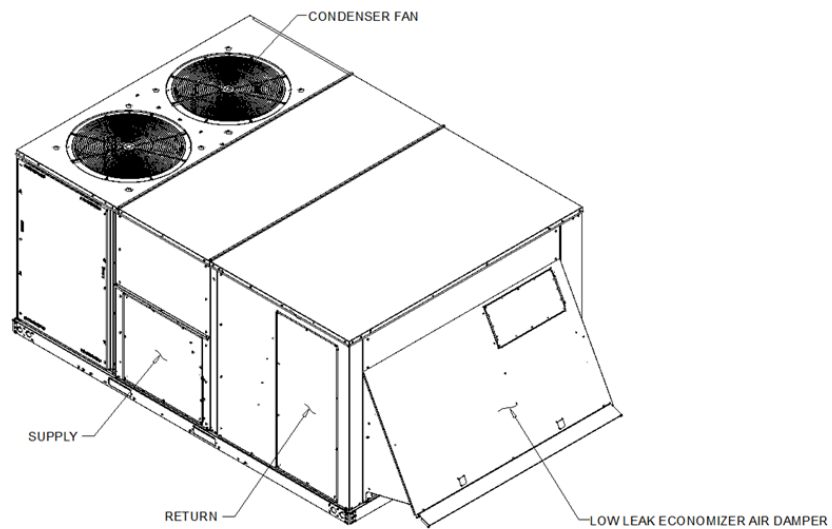

LOW LEAK ECONOMIZER AIR DAMPER (FIELD ACCESSORY)

DX COOLING / GAS HEAT STANDARD EFFICIENCY



Carrollton Public Schools

Field Wiring - 3 - 25 Ton Precedent Unitary Rooftop

Item: A1 Qty: 1 Tag(s): PREC-1

NOTES:
1. VERIFY WEIGHT, CONNECTION, AND ALL DIMENSION WITH INSTALLER DOCUMENTS BEFORE INSTALLATION

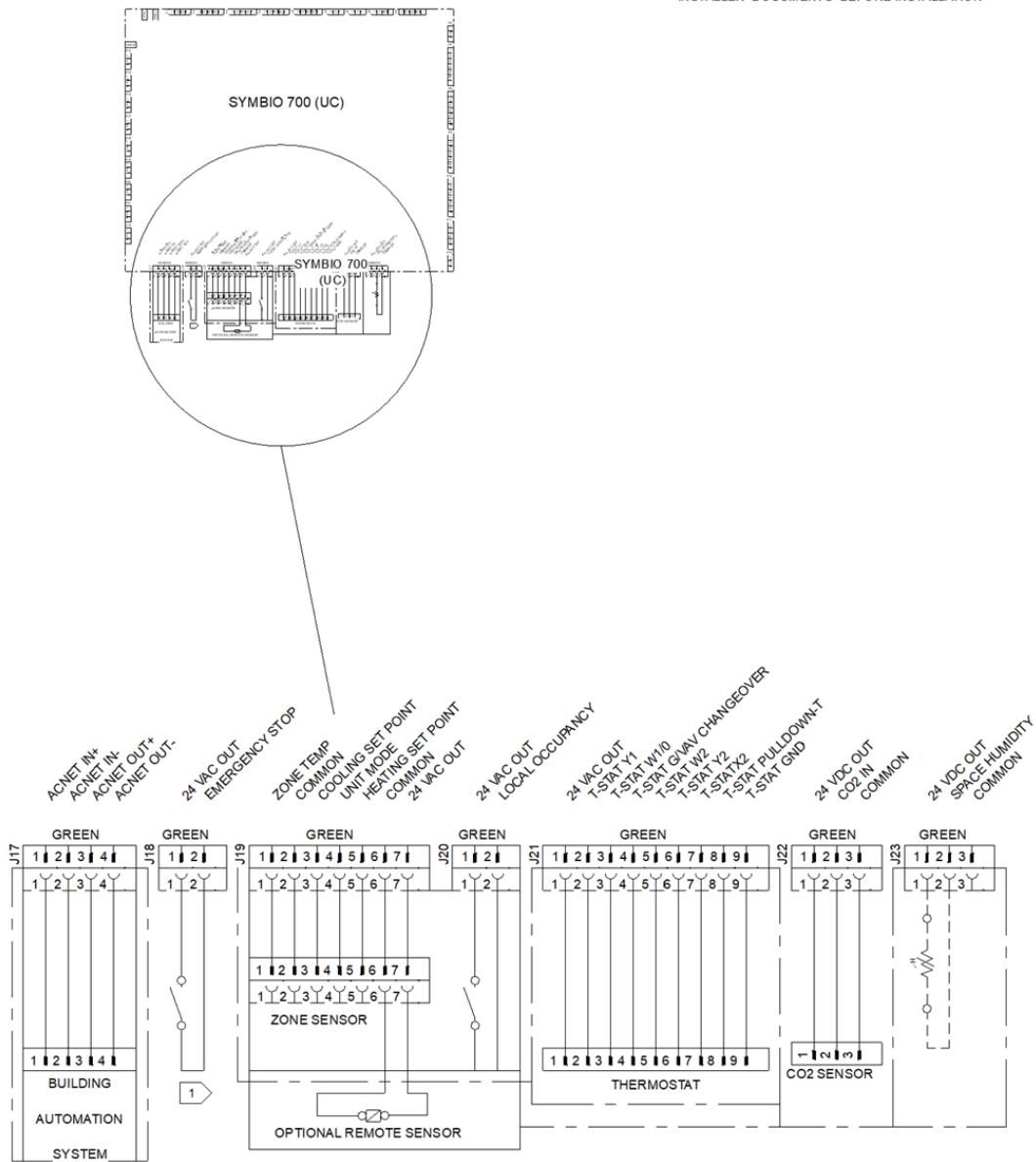

SYMBIO 700 (J17, J18, J19, J20, J21, J22, AND J23)
FIELD WIRING DRAWING



Carrollton Public Schools

Field Wiring - 3 - 25 Ton Precedent Unitary Rooftop

Item: A1 Qty: 1 Tag(s): PREC-1

NOTES:
1. VERIFY WEIGHT, CONNECTION, AND ALL DIMENSION WITH
INSTALLER DOCUMENTS BEFORE INSTALLATION

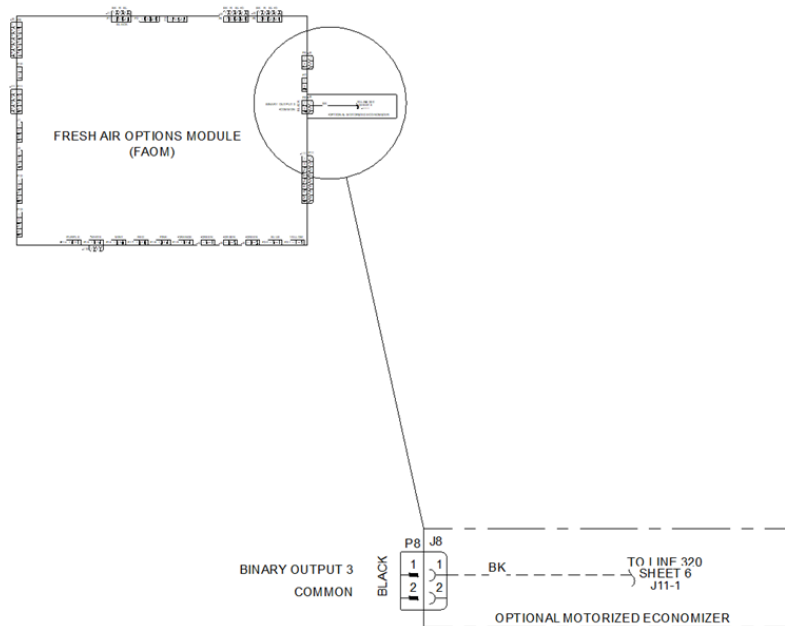

OPTIONAL MOTORIZED ECONOMIZER (J8)
FIELD WIRING DRAWING (INDOOR OPTION MODULE)



Carrollton Public Schools

Field Installed Options - Part/Order Number Summary

This is a report to help you locate field installed options that arrive at the jobsite. This report provides part or order numbers for each field installed option, and references it to a specific product tag. It is NOT intended as a bill of material for the job.

Product Family - 3 - 25 Ton Precedent Unitary Rooftop

Item	Tag(s)	Qty	Description	Model Number
A1	PREC-1	1	3 - 25 Ton Precedent Unitary Rooftops (P	YSK240A4S0H

Field Installed Option Description	Part/Ordering Number
Fresh Air Option Module	FIAOPTN002A
0-100% Low Leak Economizer kit, dry bulb control	FIAECON103A
3H/2C programmable touchscreen thermostat	BAYSTAT152A
Discharge air sensing tube	FIADAST008A



Carrollton Public Schools

SUBMISSION OF BIDS & REQUIREMENTS

1. BIDDING PROCEDURE

Due Date: Sealed bids clearly labeled “Middle School Gym RTU Replacement” will be received by Carrollton Public Schools until **Thursday, June 18th at 11 a.m. local time**, at which time bids will be publicly opened and read. Bids must be submitted on the forms provided, in a sealed envelope, clearly labeled “Middle School Gym RTU Replacement”, and delivered by the date and time stated above to:

**Tiffany Peterson - Superintendent
Carrollton Public Schools
3211 Carla Drive
Saginaw, MI 48604**

- **Late Proposals:** Proposals received after the date and time stated above will not be accepted or considered. The School District is not liable for any delivery or postal delays. All proposals received after the deadline will be returned unopened.

- **Signed Original Proposal:** Each proposal submitted must be an original hard copy and signed by an authorized member of the company. This member should be the highest-ranking officer at the local level. No oral, faxed or emailed proposals will be accepted. **To be considered, each proposal must include all of the following:**
 1. Attachment A – Bid Proposal Form
 2. Attachment B – Familial Relationship Disclosure Statement
 3. Attachment C – Iran Linked Business Affidavit
 4. Attachment D – Legislation
 5. Bid Bond/Certified Check (5%)



Carrollton Public Schools

- **Copies of Proposal:** The bidder shall also submit with its original proposal, two (2) complete copies of the signed original proposal.
- **Questions:** All questions regarding this project are to be emailed to Brady Dangler at bdangler@gocavs.net
- **Addenda to this RFP:** If it becomes necessary to revise any part of this RFP, all addenda will be posted on the School District's website and all addenda shall become a part of the RFP. Each Contractor must in its Proposal, acknowledge all addenda which it has received. The failure of a Contractor to receive, or acknowledge receipt of, any addendum shall not relieve the Contractor of the responsibility for complying with the terms thereof.
- **Reservation of Rights:** The School District reserves the right to accept or reject any or all bids, to award to other than the low bidder, to accept any and all alternates, to waive irregularities and/or informalities, and, in general, to make the award in any manner deemed by it, in its sole discretion, to be in the best interest of the School District.
- **Irrevocability of Proposals:** Bids may not be withdrawn for a period of sixty (60) days after the scheduled time of opening bids.

2. EXAMINATION OF SITE

The bidder shall be held to have examined the premises and site(s) so as to compare them with the contract specifications, and to have satisfied themselves as to the condition of the premises, obstructions, the actual levels, and other factors necessary for carrying out the work before the delivery of their proposal. The bidders shall also acquaint themselves with the character and extent of the District's operations in the area of the work, so that they may plan their services accordingly. No allowances or extra payment will be made to a Contractor for or on account of costs or expenses occasioned by failure to comply with the provisions of this paragraph, or by reason of error or oversight on the part of the bidder, or on account of interference by the Districts or other Contractor's



Carrollton Public Schools

activities. It shall be expressly understood that the District's operations will take precedence over any other activity.

3. PRE-BID MEETING

There will be a pre-bid conference and district tour for this project on June 10th, at 11 a.m. Contractors can check in to the middle school office at 3211 Carla Drive, Saginaw, MI 48617.

4. CONTRACT PERIOD

- Bid prices shall be firm through the end of this contract.
- The Owner reserves the right to suspend work wholly or in part if deemed necessary for the best interest of the Owner. This suspension will be without compensation to the Contractor, other than to adjust the contract completion/delivery requirement.
- In the event that performance on the part of any party hereto shall be delayed or suspended as a result of circumstances beyond the reasonable control and without the fault and negligence of said party, none of the parties shall incur any liability to the other parties as a result of such delay or suspension. Circumstances deemed to be beyond the control of the parties hereunder shall include, but not be limited to, acts of God or of the public enemy; insurrection; acts of the Federal Government or any unit of State or Local Government in either sovereign or contractual capacity; fires, floods; epidemics; quarantine restrictions; strikes, freight embargoes or delays in transportation, to the extent that they are not caused by the party's willful or negligent acts or omissions, and to the extent that they are beyond the party's reasonable control.

5. MODIFICATION OR WITHDRAWAL OF A BID

A bid may not be modified or withdrawn following the time and date designated for the receipt of bids. Prior to the time and date designated for receipt of bids, a submitted bid may be withdrawn by notice to the party receiving bids at the place designated for receipt of bids. Notice shall be in writing over the signature of the bidder or in person. Withdrawal notice shall be submitted by mail, telegram, or fax postmarked on or before the date and time for receipt of bids. Withdrawn bids may be resubmitted up to the time designated for the receipt of bids.



Carrollton Public Schools

6. SAFETY OF PERSONS AND PROPERTY

- The Occupational Safety and Health Acts, as amended, and as applicable, shall be enforced on this project. The successful bidders shall take all reasonable precautions for the safety of, and shall provide all reasonable protection to prevent damage, injury or loss to:
- All employees on the work and all persons who may be affected thereby.
- All the work and all materials and equipment to be incorporated therein, whether in storage on or off the site, under the care, custody or control of the successful bidders or any of his Subcontractors and Sub-subcontractors.
- Other property at the site or adjacent thereto, including trees, shrubs, lawns, walks, pavements, roadways, structures and utilities.
- The successful bidders shall comply with all applicable laws, ordinances, rules, regulations and lawful orders of any public authority having jurisdiction for the safety of persons or property or to protect them from damage, injury or loss. He shall erect and maintain, as required by existing conditions and progress of the work, all reasonable safeguards for safety and protection, including posting danger signs and other warnings against hazards, promulgating safety regulations and notifying owners and users of adjacent utilities.

7. CONTAMINATION RESPONSIBILITY

- It shall be the responsibility of the successful bidders to pay any and all costs incurred from the clean up related to any environmental hazard created by means of release, spill, leak or any other means of contamination caused by accident or negligence of the successful bidders or sub-successful bidders.
- It shall be the responsibility of the successful bidders to dispose of any product(s) and/or material following EPA, DNR, and local applicable laws and regulations.
- It shall be the responsibility of the successful bidders, if required to purchase the proper permits and notify the proper authorities prior to commencing said project or, should a "release" take place, to notify proper authorities of any such release.

8. MATERIAL SAFETY DATA SHEETS

- If the successful bidder or sub-contractor brings a hazardous chemical onto the district property, a Material Safety Data Sheet for that chemical must be submitted to the District offices.



Carrollton Public Schools

- The district keeps a file of Material Safety Data Sheets on potentially hazardous chemicals at each location.

9. SAFETY

- The Contractor shall be responsible for providing and for placing signage, barricades, tape and other safety/traffic control equipment, as appropriate, to protect its employees, the public, surrounding areas, equipment and vehicles. The flow of vehicular traffic shall not be impeded at any time during this project. The safety of the Contractor's employees and the public is of prime concern to the Owner, and the Successful bidders must take all necessary steps to assure proper safety during the performance of the Contractor. Any Bidder that has a history of safety problems or a high incidence of accidents will not be considered for award of a Contract.
- The Contractor shall keep the premises clean of all rubbish and debris generated by the work involved and shall leave the premises neat and clean. All surplus material, rubbish, and debris shall be disposed of by the Contractor at the Contractor's expense.
- The work area shall be cleaned at the end of each workday. All materials, tools, equipment, etc., shall be removed or safely stored. The District is not responsible for theft or damage to the Contractor's property. All possible safety hazards to workers or the public shall be corrected immediately and left in a safe condition at the end of each work shift. If there is a question in this area, the Director of Facilities will be consulted.
- The Owner does not assume any responsibility, at any time, for the protection of or for loss of materials, from the time that the contract operations have commenced until the final acceptance of the work by the Director of Facilities.
- The Contractor shall be responsible for all damages to the Owner's property caused by either equipment or operator error. The Owner reserves the right to repair any or all damages with other sources if the Contractor fails to do so within an expedient time to be determined by the Owner. The Contractor shall be back-charged for all costs required to complete this work.
- In the event that the Contractor causes building damage, the Contractor shall be responsible for immediate communication to the Director of Facilities.



Carrollton Public Schools

10. NO SMOKING POLICY

Carrollton Public Schools Board of Education policy prohibits the use of any tobacco product (including cigar, pipe, cigarette, snuff, or any other matter or substance that contains tobacco) in all District buildings, on all District grounds or in vehicles on District grounds.

11. PAYMENTS AND COMPLETION

Contractor shall invoice the district within thirty (30) days after work is complete. All work performed in June must be invoiced by June 30th. Invoices must include an invoice number and contain the purchase order number under which the contract is awarded. Payment to the successful bidders will be made thirty (30) days after the work is complete and accepted by Carrollton Public Schools.

12. TAXES

Federal, state and local sales and use taxes are not applicable and shall not be included in the bid price.

13. QUALIFICATION OF BIDDER

- To enable the Owner to evaluate the competency and financial responsibility of the Bidder, the Bidder, upon request, shall furnish a list of similar projects, including all school contracts, completed during the previous years, including the name and phone number of a contact person and/or a statement regarding any past, present, or pending litigation with an owner. Such additional information may be required to satisfy the Owner that the bidder is adequately prepared, in technical experience, or otherwise, to fulfill the contract.
- The bidder, upon request, shall submit information regarding names and backgrounds of the bidder's equipment operators and responsible company officials, if requested, and establish, to the satisfaction of the district, the reliability and responsibility of the persons or entities proposed to deliver the services described in the contract documents.



14. POST BID INFORMATION

The Bidder shall within seven (7) days of notification of selection for the award of the Contract for the work, submit the following information. A. Designation of the Work to be performed by the Bidder with his own forces. B. Proprietary names and the suppliers of principal items or systems of materials and equipment proposed for the Work. C. List of names of the subcontractors or other persons or entities (including those who are to furnish materials or equipment fabricated to the special design) proposed for the principal portions of the Work. D. A list of proposed job site staff and home office staff directly involved with this Project. Indicate the qualifications, pay rates, titles, responsibilities, and duties of each person. E. Certificates evidencing insurance coverage in the amounts and types specified. F. An interim construction schedule in a bar graph format. G. A completed Schedule of Values in the format provided by the Owner. The Bidder will be required to establish to the satisfaction of the Owner, the reliability and responsibility of the persons or entities proposed to furnish and perform the Work described in the Bidding Documents. Prior to the award of the Contract, the Bidder will be notified in writing. If the Owner has reasonable objection to any proposed person or entity, the Bidder may at his option, (1) withdraw his bid or (2) submit an acceptable substitute person or entity with an adjustment in cost occasioned by such substitution. The Owner may at his discretion, accept the adjusted bid price or disqualify the Bidder. The Owner reserves the right to request financial statements from the bidder before the award of a contract.

15. POST BID INTERVIEW

The selected Contractor as determined by the Owner may be required to attend a pre-contract award interview at the school for the purpose of reviewing the submitted bid for compliance with specified products, methods of installation, warranties, general job procedures, post bid information and related items. Meeting minutes of the pre-contract interview will be taken by the school district. Before concluding the interview, the minutes will be signed by those in attendance. The interview may be recorded in person or via conference call and will become part of the contract.



Carrollton Public Schools

16. LOCAL PRODUCTS

All prime bidders, subcontractors and suppliers shall utilize products that are local to the region or State whenever possible where price, quality and performance are equal to or better than non-local products.

17. MINORITY SUBCONTRACTORS

Bidders are encouraged to use the services of minority subcontractors if possible in the pursuance of this project.

18. NON-COLLUSION CLAUSE

By submitting and signing the proposal form, the bidder declares that neither the bidding firm nor agents of the bidding firm or any other members of the proposed team have entered into any collusion or agreement concerning any aspect of the proposal.

19. WARRANTY

All work shall be guaranteed for a period of twelve (12) months from the date of substantial completion of the entire project unless more specifically stated in the contract documents. All service during this 12-month period shall be rendered without charge to the Owner. This 12- month warranty does not replace any longer warranties required by the specification.

20. SUBMITTALS

Submittals of product data, shop drawings, color charts and samples are required for this project. When submitting information electronically all contractors shall use the Portable Document Format (.pdf) for all email attachments. Forms and requests that are submitted in a different format may be rejected resulting in delays to the schedule and payments.



Carrollton Public Schools

21. SWORN STATEMENTS AND WAIVERS

Sworn statements and waivers are required with every payment request. Final payment will not be issued without full unconditional waivers from all suppliers.

22. PROJECT CLOSEOUT

Closeout documents must be submitted in both paper and electronic (PDF) formats.



Carrollton Public Schools

ATTACHMENT A

BID PROPOSAL FORM

TO: Tiffany Peterson - Superintendent
Carrollton Public Schools
3211 Carla Drive
Saginaw, MI 48604

RE: Carrollton Public Schools
Middle School Gym RTU Replacement

Having carefully reviewed the bidding documents described in this RFP and understanding the scope of work involved, we hereby propose to furnish labor, materials, tools, equipment, supervision, insurance and services required for the completion of all work required for the project indicated in accordance with this RFP.

BIDDERS NAME: _____

BASE BID:

Total Base Sum of _____

_____ Dollars \$ _____

ADDENDA: And having received and examined the following Addenda: (include date for acknowledgement)

Addendum Number _____, dated _____, 2025

Addendum Number _____, dated _____, 2025

Addendum Number _____, dated _____, 2025

Addendum Number _____, dated _____, 2025

Addendum Number _____, dated _____, 2025



Carrollton Public Schools

ATTACHMENT B

FAMILIAL RELATIONSHIP DISCLOSURE STATEMENT

Important: This disclosure statement must be included with your bid as required by state law (Public Act 232 of 2004).

As required by Public Act 232 of 2004, all bids shall be accompanied by a sworn and notarized statement disclosing any familial relationship that exists between the owner of any employee of the bidder and any member of the Carrollton Board of Education or the Superintendent of Schools. The Board of Education shall not accept a bid that does not include this sworn and notarized disclosure statement.

The undersigned, the owner or authorized officer of

_____ (the "Bidder"), pursuant to the familial disclosure requirement provided in the Carrollton Public Schools invitation to bid, hereby represent and warrant, except as provided below, that no familial relationships exist between the owner(s) or any employee of the company and any member of the Carrollton Board of Education or the Superintendent of Schools. (Listing of names follows.) If such a relationship exists, please explain:

Signature: _____

Printed Name/Title: _____

Company Name: _____

Date: _____

Subscribed and Sworn to Before Me:

This _____ day of _____, 20_____ A.D., in and for the County of _____, Michigan. My commission expires _____.

Signature of Notary



Carrollton Public Schools

ATTACHMENT C

AFFIDAVIT OF COMPLIANCE – IRAN ECONOMICS SANCTIONS ACT

Michigan Public Act 517 of 2012

Important: This disclosure statement must be included with your bid as required by state law (Public Act 517 of 2012).

The undersigned, the owner or authorized officer of the below-named bidder (the "Bidder"), pursuant to the compliance certification requirement provided in the Carrollton Public Schools' (the "district") Request For Proposal (the "RFP"), hereby certifies, represents and warrants that the Bidder (including its officers, directors and employees) is not an "Iran linked business" within the meaning of the Iran Economic Sanctions Act, Michigan Public Act No. 517 of 2012 (the "Act"), and that in the event Bidder is awarded a contract as a result of the aforementioned RFP, the Bidder will not become an "Iran linked business" at any time during the course of performing services under the contract.

The Bidder further acknowledges that any person who is found to have submitted a false certification is responsible for a civil penalty of not more than \$250,000.00 or two (2) times the amount of the contract or proposed contract for which the false certification was made, whichever is greater, the cost of the School District's investigation, and reasonable attorney fees, in addition to the fine. Moreover, any person who submitted a false certification shall be ineligible to bid on a request for proposal for three (3) years from the date that it is determined that the person has submitted the false certification.

Signature: _____

Printed Name/Title: _____

Company Name: _____

Date: _____

Subscribed and Sworn to Before Me:

This _____ day of _____, 20____ A.D., in and for the County of _____, Michigan. My commission expires _____.

Signature of Notary



Carrollton Public Schools

ATTACHMENT D

LEGISLATION

The undersigned, the owner or authorized officer of (the "Bidder"), certifies to Carrollton Public School District, that any and all persons who will work directly or indirectly for the Bidder, including, but not limited to, Bidder's employees, agents, vendors, subcontractors or consultants, and who will work at or on any District property, shall at all times be in compliance with MCL. 380.1230, 380.1230a, 380.1230c, 380.120d, and 380.1230g and have not been convicted of any "listed offenses". The Bidder further warrants and represents that all persons who work directly or indirectly for the Bidder, including, but not limited to, Bidders employees, agents, vendors, subcontractors or consultants, and who will work on or at the Districts' property, shall at all times be in compliance with MCL 380.1230, 380.1230a, 380.1230c, 380.1230d and 380.1230g. In this regard, Bidder agrees, without limitation, to report within three (3) business days to the District when any such person is charged with a crime listed in Section 1535a(1) of the Revised School Codes or a subsequently convicted, pled guilty or pled no contest to that crime.

Bidder: _____

By: _____

Its: _____